



Parks and Recreation Board Meeting

Wednesday, December 21, 2022 at 6:00 pm

1. CALL TO ORDER, PRAYER AND PLEDGE
2. ROLL CALL
3. APPOINT CHAIR AND VICE-CHAIR
4. ADDITIONS/DELETIONS/CHANGES
5. CONSENT AGENDA

- a. Approve Minutes of 10/17/2022

Exhibit: Agenda Report Number 6a

Attachments:

- **Agenda Report Number 5a** (Agenda_Report_Number_5a.pdf)

6. PUBLIC COMMENTS

7. ACTION ITEMS

- a. FCT Grant Agreement Amendment

Exhibit: Agenda Report Number 8a

Attachments:

- **Agenda Report Number 7a** (Agenda_Report_Number_7a.pdf)

8. DISCUSSION

9. OLD/NEW BUSINESS

- a. Board Member Reports
- b. Staff Reports
- c. Next Scheduled Meeting

10. ADJOURNMENT

Contact: Richard W. Kohler (rkohler@townofmalabar.org (321)-727-7764) | Agenda published on
11/14/2022 at 5:07 PM

TOWN OF MALABAR

PARKS AND RECREATION BOARD MEETING

AGENDA ITEM NO: 5.a
Meeting Date: November 15, 2022

Prepared By: Richard W. Kohler, Town Clerk

SUBJECT: Approval of Minutes of 10/19/2022

BACKGROUND/HISTORY:

- a. Summary of actions at the Parks and Recreation Board Meeting of 10/19/2022

ATTACHMENTS:

- a. Draft Minutes of the 10/19/2022 Parks and Recreation Board Meeting

ACTION OPTIONS:

- a. Request Approval

The following draft minutes are subject to changes and/or revisions by the Park Board and shall not be considered the official minutes until approved by the Park Board.

**TOWN OF MALABAR – PARKS AND RECREATION ADVISORY BOARD
October 19, 2022, MEETING MINUTES**

This meeting of the Malabar Parks and Rec Board was held at Town Hall at 2725 Malabar Road. It was called to order by Chair Bienvenu at 6:00 pm. Prayer and pledge were led by Chair Bienvenu.

1. CALL TO ORDER, PRAYER, AND PLEDGE

2. ROLL CALL

Chair	Eric Bienvenu - Present
Vice-Chair	Vicky Thomas – Present
Members	Tom Taylor – Present
	Jennifer Bienvenu – Present
	Hans Kemmler - Present
	Parnel Jean – EXCUSED
	Evan Hall – Present
Recording Secretary	Richard Kohler – Present

Public

3. ADDITIONS/DELETIONS/CHANGES: NONE

4. CONSENT AGENDA

a) Approval of Minutes of 4/20/2022

MOTION: Thomas/Bienvenu to accept the minutes of 4/20/2022 as amended.

VOTE: All Ayes

5. PUBLIC COMMENTS

6. ACTION ITEMS:

7. DISCUSSION:

a. Fiscal Year 2022/2023 Goals

Secretary Kohler gave a brief overview of the projects discussed in the last year. Chair Bienvenu gave a brief explanation of the dog park project. VC Thomas stated that in her research, she didn't find much support from residents. BM Kemmler asks which location would get more use for the pavilion? Consensus is Cameron Preserve. VC Thomas states Eschenberg Park has more parking and gets use from several road bikers. BM Taylor states the use of the park has increased. BM Kemmler states that the pavilion at Huggins Park was never used, and when we moved it to the Golf Sanctuary it got lots of use. VC Thomas states that putting a pavilion at Eschenberg could turn it into a park where people can have parties and events. BM Taylor states he believes the current suggested pavilion is too small to protect people from rain or summer sun. BM Bienvenu states this quote covers exactly what the Board asked for. BM Taylor suggests changing the specs to be larger. BM Kemmler suggests keeping the same specs. BM Hall states if it is going in at Eschenberg, the risk of fire is less likely. BM Bienvenu states the quickest way to get a pavilion is to ask Council to support the current quote.

BM Bienvenu/BM Kemmler Move to recommend to Council that the quoted pavilion from Pro Playgrounds be purchased, to be installed in Eschenberg Park.

Motion Carries 4-1 (Taylor Nay)

8. OLD/NEW BUSINESS:

a) BOARD MEMBER/STAFF REPORTS:

- Richard E. Cameron & Volunteers Wilderness Preserve – VC Thomas thanked the Trails and Greenways Committee for their hard work at the Cameron Preserve. They expedited the clean up after the Storm. Berry pickers have made a mess, but it has been cleaned up. Use of the park has increased a lot. BM Kemmler installed a few posts under the picnic bench there and it works very well. She would also support a smaller pavilion in the preserve, possibly with a veteran's memorial. Chair suggests combining forces with the T&GC to get a pavilion there eventually. She also thanked the Public Works department for their maintenance of the area.
 - Disc Golf Sanctuary – BM Kemmler states the sanctuary is in good shape. They are working on updating their signs. The crew has worked to remove all palm fronds knocked down during Ian. The PW crew has done an excellent job mowing and maintaining the area. There is still a pile of debris on the third fairway.
 - Thomas Eschenberg Memorial Conservation Area – None.
 - Malabar Community Park – BM Bienvenu asks about the Malabar Historical House. BM Kemmler states there has been no progress.
 - Sandhill Trail Head – BM Hall states the park was carpeted with palm fronds, but they have been removed. There have been some negative actors in the area, but they have been removed.
 - BM Kemmler suggests improving the Town Seal outside Town Hall. VC Thomas suggests making the PW position part time to allow people to take it on as a second job. BM Taylor suggests using an outside contractor to fill PW positions.
- b) Staff Reports – Secretary Kohler informed the Board that the Trails and Greenways Committee has purchased and will be installing several signs in and around the Cameron Preserve. Staff has received increased reports of vagrants in the parks, particularly Sandhill Trailhead. BCSO has been notified. He also informed the Board that Alternate Member Parnel Jean will not be renewing his membership, citing an increased workload. He stated that when his work schedule returns to normal, he looks forward to rejoining the Board.
- c) Next Scheduled Meeting

- November 16th, 2022, 6 PM

9. ADJOURNMENT

There being no further discussion. **MOTION: Bienvenu/Kemmler motion to adjourn the meeting**
VOTE: All Ayes. This meeting adjourned at 6:54 pm.

By:

Eric Bienvenu, Chair

ATTEST:

Richard W. Kohler
Recording Secretary

Date Approved: _____

NOTE: THERE MAY BE ONE OR MORE MALABAR ELECTED OFFICIAL ATTENDING THIS MEETING

If an individual decides to appeal any decision made by this board with respect to any matter considered at this meeting, a verbatim transcript may be required, and the individual may need to ensure that a verbatim transcript of the proceedings is made (Florida Statute 286.0105). The Town does not provide this service. In compliance with the Americans with Disabilities Act (ADA), anyone who needs a special accommodation for this meeting should contact the Town's ADA Coordinator at 321-727-7764 at least 48 hours in advance of this meeting.

TOWN OF MALABAR

PARKS AND RECREATION BOARD MEETING

AGENDA ITEM NO: 7.a

Meeting Date: November 15, 2022

Prepared By: Richard W. Kohler, Town Clerk

SUBJECT: FCT Grant Agreement Amendment

BACKGROUND/HISTORY:

- a. Florida Communities Trust (FCT) provided Malabar \$40,445.00 in restricted funds for the transfer of the property known as Fern Creek Park.
- b. In April of 2020, an agreement was signed by the Town that required the following enhancements be provided at FCT properties around Town:
 - a. New Pavilion
 - b. Bird Watching Platform/Deck
 - c. Two Foot Bridges
 - d. New Plant and Wildlife Identification Signs
 - e. Dog Park Area (Fencing, Water Source, Trash Receptacles)
- c. It has since been determined that the funding provided would be inadequate to accomplish all the above listed tasks.
- d. The Parks and Recreation Board has selected and made a recommendation to Council to purchase a \$39,278.20 pavilion for Eschenburg Park. That leaves \$1,166.80 to develop the remaining items.
- e. Malabar Town Council has already stated a Dog Park is not a current priority, leaving the New Plant/Wildlife Identification signs, and two foot bridges.
- f. The FCT has agreed to review an amended agreement, and has requested the Town provide:
 - a. A revised list of improvements, including a brief description.
 - b. An estimated Date of Completion (Month and Year).
 - c. A dollar amount. (Estimate for pavilion)
 - d. Include backup documents and a conceptual site plan.

ATTACHMENTS:

- a. Original Signed Agreement with FCT
- b. Email from FCT Employee to TM Stinnett
- c. Quote for Pavilion

ACTION OPTIONS:

- a. Discussion

The East 200 feet of the North one-quarter of Lot 32, Section 2, Township 29 South, Range 37 East, PLAT OF FLORIDA INDIAN RIVER LAND COMPANY SUBDIVISION, as recorded in Plat Book 1, Page 165, Public Records of Brevard County, Florida, LESS the North 35.0 feet and the East 35.0 feet for road, utility, and drainage right of way and subject to easements and road rights of way of record.

The remaining parcels subject to the restrictions in the Grant Award Agreement recorded in the Official Records of Brevard County, Florida, at book number 3975, page 2450 will remain encumbered by the covenants and restrictions set forth in that Agreement.

In addition, the Town of Malabar is required to use the condemnation award in the amount of \$40,445.00 for the following enhancements to the remainder of the Project Site:

- New pavilion;
- Bird watching platform/deck;
- Two foot-bridges;
- New plant and wildlife identification signs and
- Dog park area (fencing, water source, trash receptacles).

Failure to use the condemnation award on the facilities described above will constitute a default under the original Grant Award Agreement and this Amendment.

IN WITNESS WHEREOF, the said grantor has caused these presents to be executed in its name by its Chair, the date first above written.

RECIPIENT: TOWN OF MALABAR,
a Florida local government

Debbie Franklin
Witness Signature

By: Patrick T. Reilly
Chair Patrick T. Reilly

Debbie Franklin
Printed Name

Date: April 29, 2020

Debbie K. Franklin
Witness Signature

Approved for Form and Sufficiency:

Debbie K. Franklin
Printed Name

By: Karl W. Bohwe, Jr.
Karl W. Bohwe, Jr.

From: Bibby, Bill Bill.Bibby@FloridaDEP.gov
Subject: RE: Malabar Grant
Date: November 4, 2022 at 9:46 AM
To: Matt Stinnett TownManager@townofmalabar.org
Cc: Reeves, Linda Linda.Reeves@FloridaDEP.gov, McMahon, William William.McMahon@FloridaDEP.gov, Roaza, Erin Erin.Roaza@FloridaDEP.gov, LaSeur, Lois Lois.LaSeur@FloridaDEP.gov, Jones, Ramsey L. Ramsey.L.Jones@FloridaDEP.gov

Good Morning Matt:

I have researched our files to get background on this issue. I do see a way forward.

But first, a brief discussion of the amended grant agreement. By virtue of the fact that the five improvements are expressly stated in the amended agreement, FCT considers that list to be a commitment on the part of the Town. To state clearly, the five improvements are required elements of the amended agreement. Thus, the Town would be obligated to complete all five facilities.

Given the costs involved and the fact that the Town Council has already taken the dog park off the table, it is clear that an amendment to the Amended Grant Agreement is necessary. Before we can begin drafting an amendment, we need to come to agreement on a more detailed list and description of improvements to be funded by the \$40,445 FDOT payout. Please provide a revised list of improvements, including a brief description of the improvement, an estimated date (month and year) of completion for the element and a dollar amount. Include any backup documents that you think necessary, such as the estimate on the pavilion. Also include a conceptual site plan showing the location of the improvements. Make certain this list exhausts the \$40,445 payout.

FCT will review the proposed list of improvements. We may (or may not) have comments or suggestions on the revised list. Once FCT approves the list, we will draft an amendment for execution.

We look forward to working with you to bring this issue to resolution. Let me know if you have questions

Thank you.



Bill Bibby, FCCM

Florida Department of Environmental Protection
Division of State Lands/Florida Communities Trust
Planner IV

Bill.Bibby@FloridaDEP.gov

FloridaCommunitiesTrust@FloridaDEP.gov

Office: 850-245-2783

From: Matt Stinnett <TownManager@townofmalabar.org>
Sent: Thursday, November 3, 2022 2:50 PM
To: Bibby, Bill <Bill.Bibby@FloridaDEP.gov>
Cc: Reeves, Linda <Linda.Reeves@FloridaDEP.gov>
Subject: Malabar Grant

EXTERNAL MESSAGE



TRUST == *the* == EXPERTS

For over a decade, our customers have entrusted us to provide safe and affordable playground and recreational equipment. Our team of Certified General Contractors and Playground Safety Inspectors will insure that your project is completed to perfection, providing truly turnkey service, with every step of the process from planning and budgeting, through the installation being handled under one roof.



1-800-573-7529 | www.proplaygrounds.com

Playground Equipment

- Over 200 commercial play units, plus endless customized design options, all IPEMA certified.
- Full line of accessory units including swing sets, spring riders, rope and rock climbers and more.
- Industry leading lifetime warranty and affordable pricing.
- Professionally installed by CPSI and CGC.



Shade Structures

- Large catalog of pre-designed units including hip and ridge shades, cantilever and umbrella shades.
- Broad design capability and customization to meet your shade needs, both standard and sails.
- 95% UV blocking, keeps people and equipment cool and protected.
- Compliant with FBC wind load requirements.

Surfacing Products

- Poured in place rubber surfacing for playgrounds, splash pads, entry ways, etc.
- Over 50 varieties of artificial turf for leisure, play, animal and sport applications.
- Eco friendly recycled rubber mulch for playground surfacing.
- Professional installation by certified installers.



Site Amenities and Dog Park

- Full catalog of benches and tables to meet your needs with custom colors, logos, finishes, etc.
- Trash receptacles, dog waste stations, grills, bike racks, bleachers and more, all customizable.
- Dog park accessories including obstacle courses, waste and watering stations, etc.
- Custom amenities, fire pits, ADA, etc.

Fitness and Athletic Equipment

- Selection of products for athletic needs including basketball, soccer and football goals.
- Outdoor fitness equipment for exercising, including cardiovascular and strength training products.
- Commercial grade products constructed with durable materials to ensure a lifetime of use.





Pro Playgrounds
8490 Cabin Hill Road
Tallahassee, FL 32311

Quote

Date	Estimate #
7/7/2022	15950

Project Name
Malabar Pavilion



Customer / Bill To
Town of Malabar Lisa Morrell 2725 Malabar Rd. Malabar, FL 32950

Ship To
Town of Malabar Lisa Morrell 2725 Malabar Rd. Malabar, FL 32950



WE WILL BEAT ANY PRICE BY 5%!

Item	Description	Qty	Cost	Total:
CSSD	**SHELTER** Steelworx Shelter, 12x24 Hip with 8'eave, 4:12 pitch, powdercoated, 24ga multirib roofing, 4 columns	1	15,050.00	15,050.00
ENGDRAW	Engineered Drawings for Permitting	1	1,080.00	1,080.00
Shipping	Combined Shipping and Freight Charges	1	4,560.00	4,560.00
	Raw Materials			
RMC	Ready Mix Concrete 2500 PSI MIN	6	195.00	1,170.00
RBAR5	No. 5 Rebar	200	1.75	350.00
	Labor and Installation			
FLIFTDAY	Telescopic Fork Lift Daily Rental	1	1,308.10	1,308.10
DELFFEE	Equipment Delivery / Pick Up Fees	1	300.00	300.00
LBR	Labor and Installation	1	12,585.10	12,585.10
PT	Portable Toilet	1	150.00	150.00
TRSH	Fees for dumpsters, debris hauling or other trash/materials removal including spoils from excavations.	1	725.00	725.00
ISPERMIT	PERMIT - STATE OF FLORIDA - COST NOT INCLUDED IN PRICE, COST SHALL BE \$2000 OR 5% OF TOTAL PROJECT COST, WHICHEVER IS GREATER. PRICE DOES NOT INCLUDE COST OF ENGINEERING OR SEALED DRAWINGS.		2,000.00	2,000.00

AGREED AND ACCEPTED:
If the above total price, scope of work, specifications, terms and conditions are acceptable, sign below indicating your acceptance and authorization for Pro Playgrounds to proceed with the work and/or sales transaction described in this quotation. Upon signature and payment in accordance with this quote, Pro Playgrounds will proceed with the work and/or sales transaction.

_____/_____/_____
Signature Name / Title Date

Subtotal:	\$39,278.20
Sales Tax: (7.5%)	\$0.00
Total:	<u>\$39,278.20</u>

Terms and Conditions - Price valid for 30 days and subject to change. 1. If installation is not included with your purchase, client will be responsible for coordinating, receiving and unloading of all goods, delivery drivers will not help unload goods. 2. Client will be responsible to inspect goods for defect, damage or missing parts, any deficiency or missing parts must be noted on delivery slip. 3. Client will be responsible for costs due to cancelled or missed delivery appointments. 4. Client has reviewed all items, colors and descriptions on this quote for accuracy and correctness. 5. If quote includes installation of goods, the installation is subject to the terms and conditions of Pro Playgrounds "Standard Installation Agreement" a copy of which may be obtained from your Sales Representative.

Model: Steelworx Hip Shelter, 12' x 24'
Model # HP-1224-SW

Manufacturing Mission: To provide all prefabricated components and installation instructions for a 12' wide (measured from eave to eave) by 24' long free standing bolt together, tubular steel constructed shelter kit.

Design Criteria: Structure is typically designed for a 25 lb live load and a 90 mph wind load capacity, but can be designed based on specific site requirements upon request. All structural members are ASTM A-500 U.S. grade B steel. Welded connection plates shall be ASTM A-36 hot rolled steel. All welding performed to latest AWS standards by ASTM Certified welders and provided in accordance to same.

Tubular Steel Columns and Beams: Standard column dimension shall be 5" x 5" x 3/16" tubular steel welded to 5/8" base plate. Main support beams are 7" x 5" x 3/16" and purlins are 6" x 3" x 1/8". All framing connections are done using A325 grade bolts within concealed access openings from above and will later be concealed by the roofing. All roof framing shall be flush against the roof decking to eliminate the possibility of bird nesting. Steel sizes are preliminary and may change upon final engineering based on actual site conditions and load requirements (site specific engineering shall be an additional cost).

Roofing: 24 Ga. pre-cut steel panels with Kynar 500 finish in a variety of colors with white underside. Standard roof slope is a 4/12 pitch with a eave height of 8'-0". Also available with 6/12 or 8/12 pitch roof. Attached to structural framing with engineered strength self tapping screws.

Frame Finish: All steel framework will receive a corrosion protective TGIC Polyester powder coat, electro-statically applied and cured at 400°F. A large selection of standard colors are available.

Foundation: All columns need to be anchored to concrete footings (footing design provided separately). Columns can be surface mounted with anchor bolts at or below finish slab elevation or they can be embedded directly into the footing. Optional base plate covers are available at an additional cost.

Hardware: All structural hardware and roofing fasteners shall be provided.

Not Included: Concrete work of any kind, unloading of product and installation.

Additional Options:

- Flexibility of Design
 - Such as: Height and Pitch
- Additional Engineering
- Variety of Colors
- Decorative Railings, Lattice, Braces, Trim, etc.
- Cupolas and Rooftop Accs.
- Column Style Variations
- Lexan Wind Screens
- Standing Seam Roofing
- Composite Finished Ceiling
- Solar Panels & Solar Lighting
- Site Furnishings and Accs.

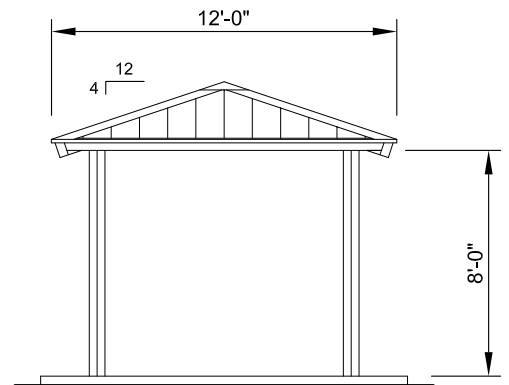

SIDE ELEVATION
SCALE: NTS

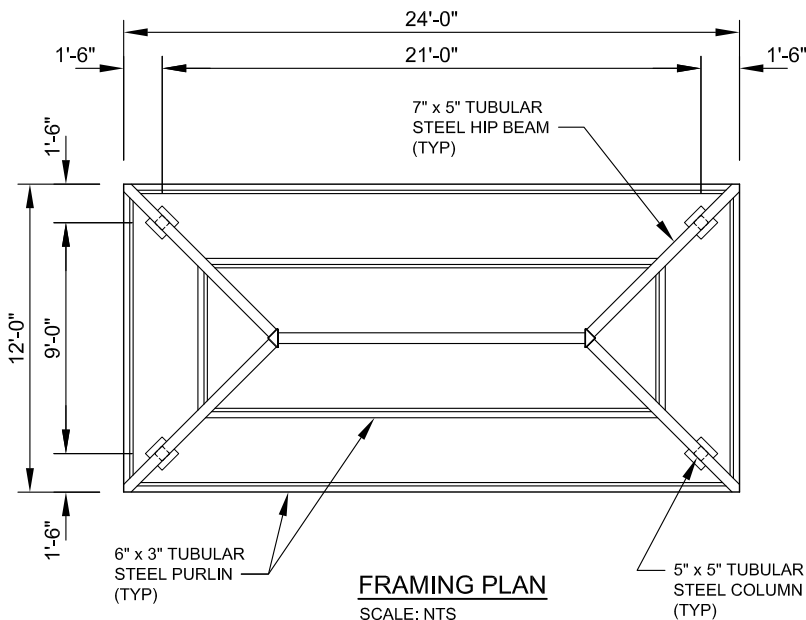

FRAMING PLAN
SCALE: NTS

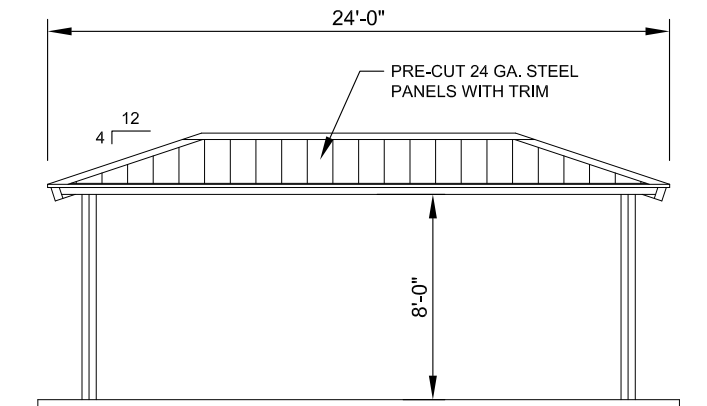

FRONT ELEVATION
SCALE: NTS



11800 East 9 Mile Road
 Warren, MI 48089
 Office: (586) 486-1088
 Fax: (586) 754-9130
 Toll Free: (800) 657-6118
 Email: info@coverworx.net
 www.CoverWorx.net

Steelworx Hip Shelter - 12' x 24'

Model: HP-1224-SW

DESIGN SPECIFICATIONS



THE PRO PLAYGROUNDS DIFFERENCE

Equipment and Products

When you purchase playground equipment from us, you're buying direct. This means that you are getting the absolute lowest price possible. We do not utilize sales reps, middle men or distributors like many of our competitors do, this gives you more purchasing power. We have hundreds of playgrounds available for purchase and can custom design most anything to meet your needs. We have a vast product offering including shade structures, site amenities and playground surfacing like artificial turf and poured in place rubber.

Installation

We are one of only a few companies in the United States that actually service and install the products we sell in house. This means that the person you speak to when you buy your playground may very well be the person who installs it. Our competitors use local sub contractors, many of whom know nothing about installing a playground or playground safety, and worse many of whom are unlicensed, uninsured and a high risk.

Services

We are truly a full service parks and recreations firm. We take care of every aspect of your playground project in house, from the design, to the sale to the installation. We have in house capabilities that are unmatched by our competitors. From traditional construction needs like sidewalks, to the safety surfacing including poured in place rubber and rubber turf, a single contractor with a huge list of capabilities. Our competitors subcontract these services, that means higher prices, lower quality, longer lead times and a lack of accountability.

Licensing

We are State Certified General Contractors and licensed Playground Safety Inspectors. This means that we have the knowledge, experience and legal ability to complete your project. Many firms that install playground equipment are unlicensed, inexperienced and uninsured.

Experience

We have designed and installed over 100 playgrounds in the USA, from start to finish. We have experience with projects as small as \$5,000 and as large as \$500,000. Our firm has provided expert testimony in court cases involving playground equipment. When it comes to playgrounds, we are the experts.

Accountability

We still believe that the customer is always right. We also feel that our responsibilities to our customers do not end once we have completed a sale, in fact that's when they truly begin. Our service after the sale is unparalleled. If you have any problems or issues with your equipment, we resolve the problems in house. Our competitors have only one concern and that is closing the sale.